

L:
 CBL-HFD3SAB5CS-4m 4000mm±30mm
 CBL-HFD3SAB6CS-5m 5000mm±30mm
 CBL-HFD3SAB6CS-6m 6000mm±30mm

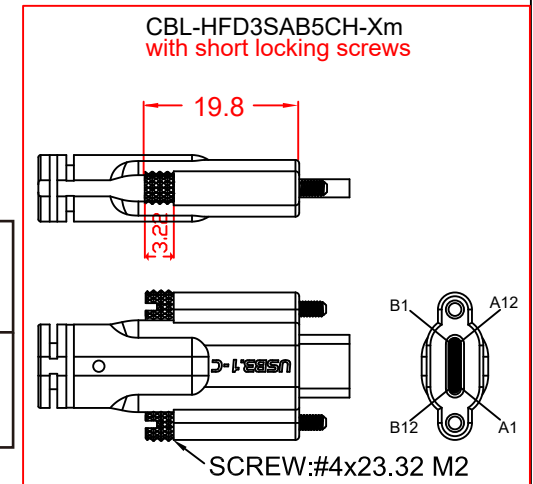
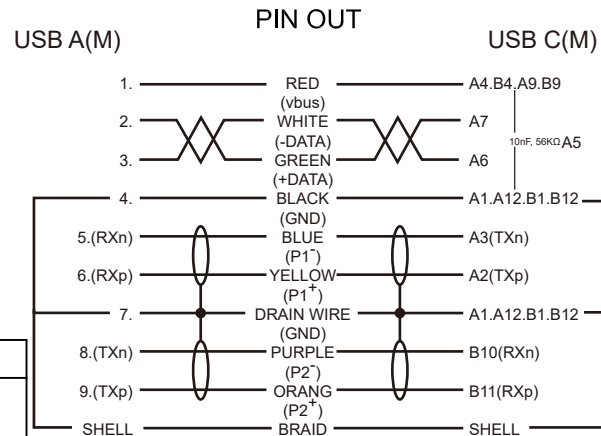

No	MATERIALS LIST:
1.	CABLE: 3 x (2 x 28 AWG)ST + 2 x 26 AWG O.D.:.6.1mm COLOR:RED LILAC
2.	CONNECTOR:USB 3.0 A/M, 9P, BLUE INSULATOR SOLDER TYPE, NICKEL PLATED SHELL
3.	CONNECTOR:USB 3.1 TYPE-C, MALE, NICKEL PLATED SHELL
4.	PVC MOLDED HOUSING, BLACK COLOR
5.	SCREW:#4x33 M2

Jargy part no.	Client part no.	Approved	SCALE	UNIT
CBL-HFD3SAB5CS-xm				mm
Drawing Name		Drawn	Date	REV.
USB 3.1 GEN 1 A to C Cable M/M				1.0

Mobile Computing JARGY

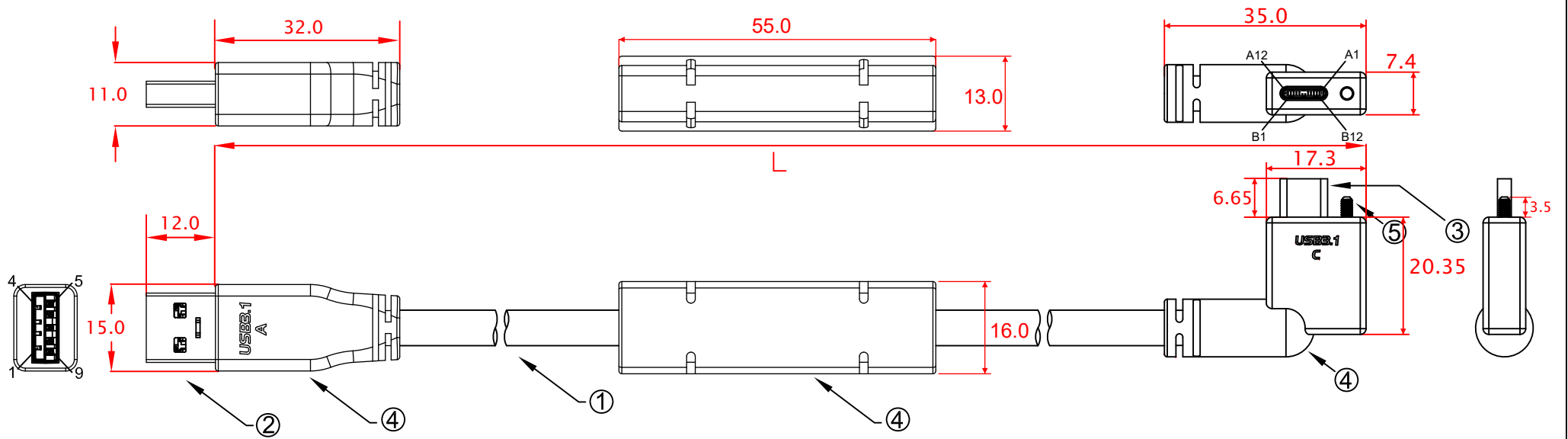

L:
 CBL-HFD3SAB5CH-4mLRA 4000mm±30mm
 CBL-HFD3SAB6CH-5mLRA 5000mm±30mm
 CBL-HFD3SAB6CH-6mLRA 6000mm±30mm

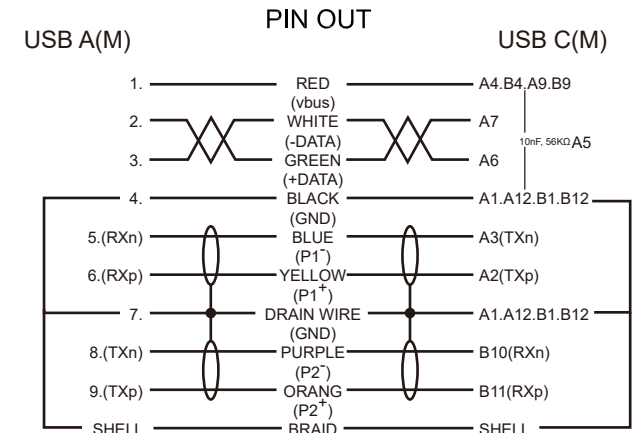

No	MATERIALS LIST:
1.	CABLE: 3 x (2 x 28 AWG)ST + 2 x 26 AWG O.D.:.6.1mm COLOR:RED LILAC
2.	CONNECTOR:USB 3.0 A/M, 9P, BLUE INSULATOR SOLDER TYPE, NICKEL PLATED SHELL
3.	CONNECTOR:USB 3.1 TYPE-C, MALE, NICKEL PLATED SHELL
4.	PVC MOLDED HOUSING, BLACK COLOR
5.	SCREW:#4x23.32 M2

Jargy part no.	Client part no.	Approved	SCALE	UNIT
CBL-HFD3SAB5CH-xmLRA				mm
Drawing Name		Drawn	Date	REV.
USB 3.1 GEN 1 A to C Cable M/M				1.0

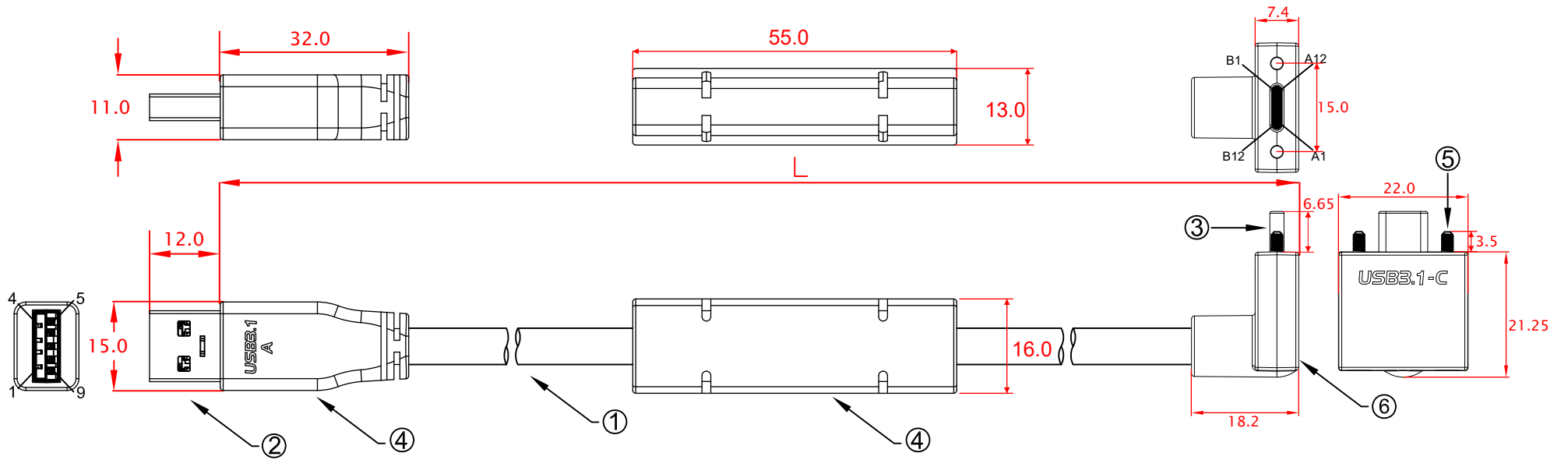

L:
 CBL-HFD3SAB5CH-4mUDA 4000mm±30mm
 CBL-HFD3SAB6CH-5mUDA 5000mm±30mm
 CBL-HFD3SAB6CH-6mUDA 6000mm±30mm

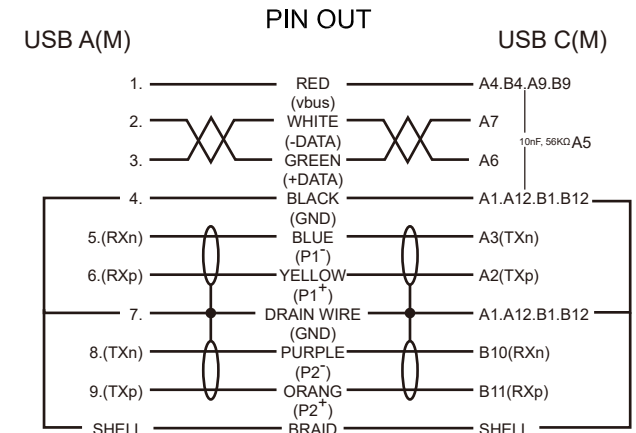

No	MATERIALS LIST:
1.	CABLE: 3 x (2 x 28 AWG)ST + 2 x 26 AWG O.D.:.6.1mm COLOR:RED LILAC
2.	CONNECTOR:USB 3.0 A/M, 9P, BLUE INSULATOR SOLDER TYPE, NICKEL PLATED SHELL
3.	CONNECTOR:USB 3.1 TYPE-C, MALE, NICKEL PLATED SHELL
4.	PVC MOLDED HOUSING, BLACK COLOR
5.	SCREW:#4x23.32 M2
6.	ABS ASSEMBLY HOUSING, BLACK COLOR

Jargy part no.	Client part no.	Approved	SCALE	UNIT
CBL-HFD3SAB5CH-xmUDA				mm
Drawing Name		Drawn	Date	REV.
USB 3.1 GEN 1 A to C Cable M/M				1.0

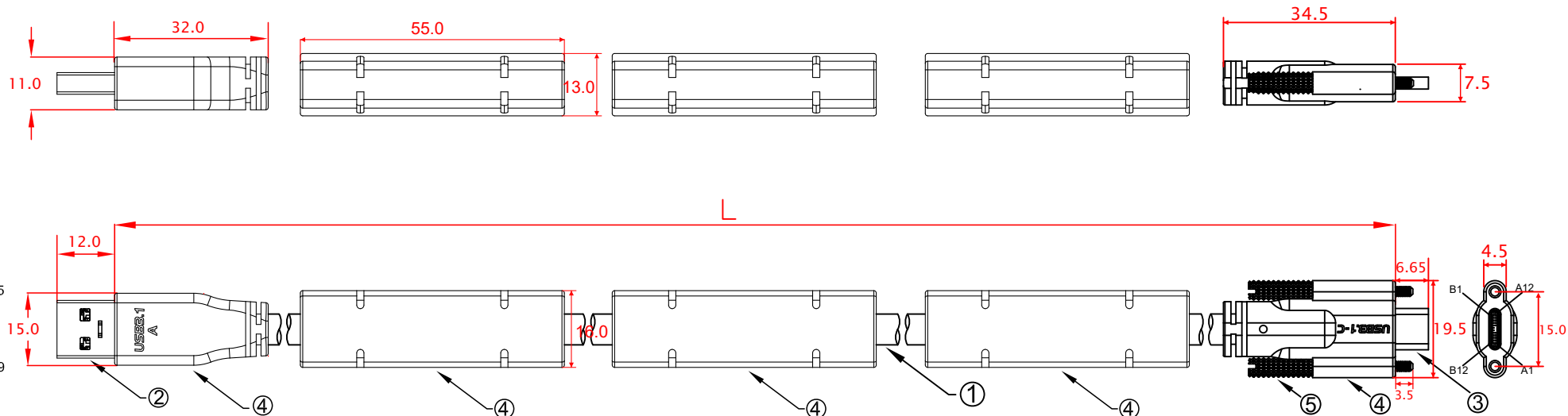

L:
 CBL-HFD3SAB5CS-7m 7000mm±50mm
 CBL-HFD3SAB5CS-8m 8000mm±50mm
 CBL-HFD3SAB5CS-9m 9000mm±50mm

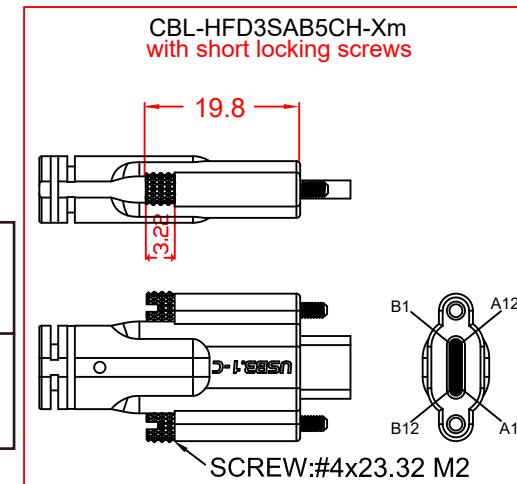
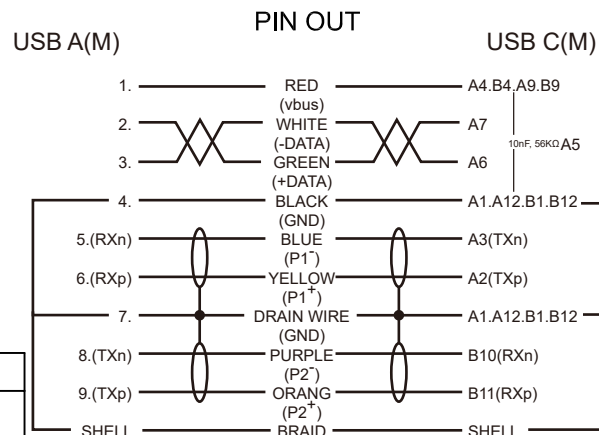

No	MATERIALS LIST:
1.	CABLE: 3 x (2 x 28 AWG)ST + 2 x 26 AWG O.D.:.6.1mm COLOR:RED LILAC
2.	CONNECTOR:USB 3.0 A/M, 9P, BLUE INSULATOR SOLDER TYPE, NICKEL PLATED SHELL
3.	CONNECTOR:USB 3.1 TYPE-C, MALE, NICKEL PLATED SHELL
4.	PVC MOLDED HOUSING, BLACK COLOR
5.	SCREW:#4x33 M2

Jargy part no.	Client part no.	Approved	SCALE	UNIT
CBL-HFD3SAB5CS-xm				mm
Drawing Name		Drawn	Date	REV.
USB 3.1 GEN 1 A to C Cable M/M				1.0

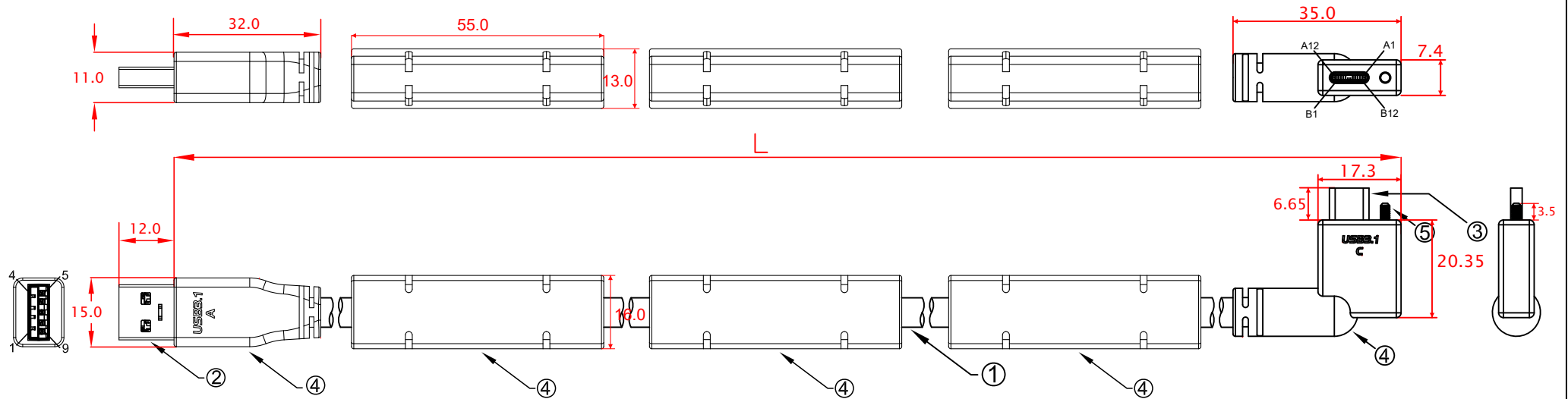

L:
 CBL-HFD3SAB5CH-7mLRA 7000mm±50mm
 CBL-HFD3SAB5CH-8mLRA 8000mm±50mm
 CBL-HFD3SAB5CH-9mLRA 9000mm±50mm

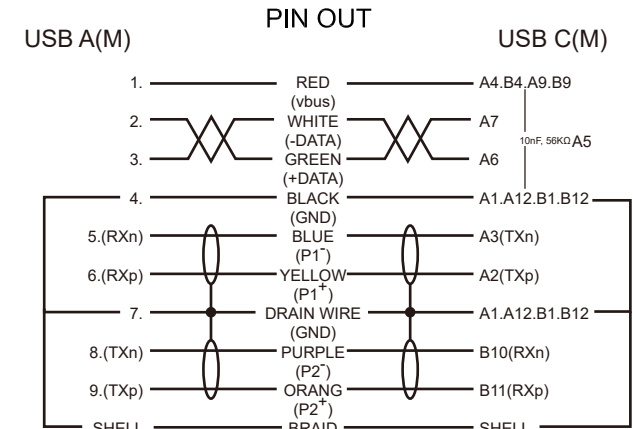

No	MATERIALS LIST:
1.	CABLE: 3 x (2 x 28 AWG)ST + 2 x 26 AWG O.D.:.6.1mm COLOR:RED LILAC
2.	CONNECTOR:USB 3.0 A/M, 9P, BLUE INSULATOR SOLDER TYPE, NICKEL PLATED SHELL
3.	CONNECTOR:USB 3.1 TYPE-C, MALE, NICKEL PLATED SHELL
4.	PVC MOLDED HOUSING, BLACK COLOR
5.	SCREW:#4x23.32 M2

Jargy part no.	Client part no.	Approved	SCALE	UNIT
CBL-HFD3SAB5CH-xmLRA				mm
Drawing Name		Drawn	Date	REV.
USB 3.1 GEN 1 A to C Cable M/M				1.0

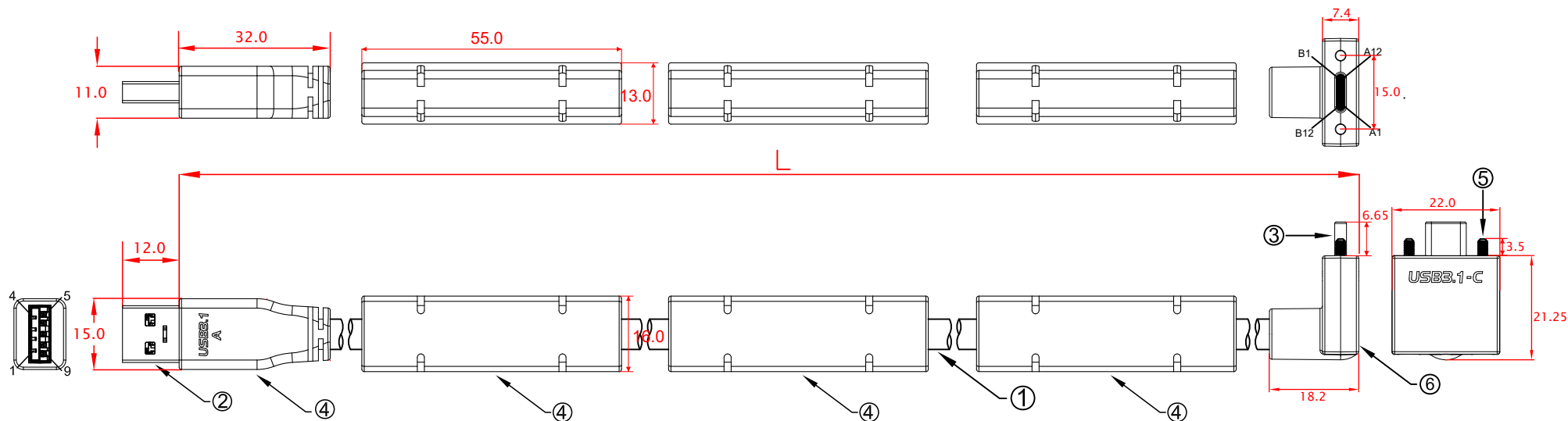

L:
 CBL-HFD3SAB5CH-7mUDA 7000mm±50mm
 CBL-HFD3SAB5CH-8mUDA 8000mm±50mm
 CBL-HFD3SAB5CH-9mUDA 9000mm±50mm

No	MATERIALS LIST:
1.	CABLE: 3 x (2 x 28 AWG)ST + 2 x 26 AWG O.D.:6.1mm COLOR:RED LILAC
2.	CONNECTOR:USB 3.0 A/M, 9P, BLUE INSULATOR SOLDER TYPE, NICKEL PLATED SHELL
3.	CONNECTOR:USB 3.1 TYPE-C, MALE, NICKEL PLATED SHELL
4.	PVC MOLDED HOUSING, BLACK COLOR
5.	SCREW:#4x23.32 M2
6.	ABS ASSEMBLY HOUSING, BLACK COLOR

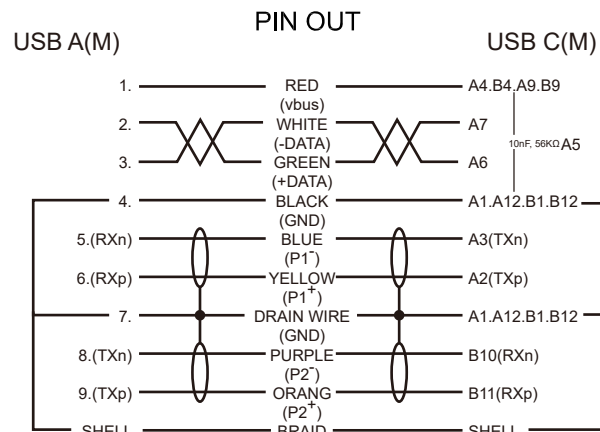

Jargy part no.	Client part no.	Approved	SCALE	UNIT
CBL-HFD3SAB5CH-xmUDA				mm
Drawing Name		Drawn	Date	REV.
USB 3.1 GEN 1 A to C Cable M/M				1.0

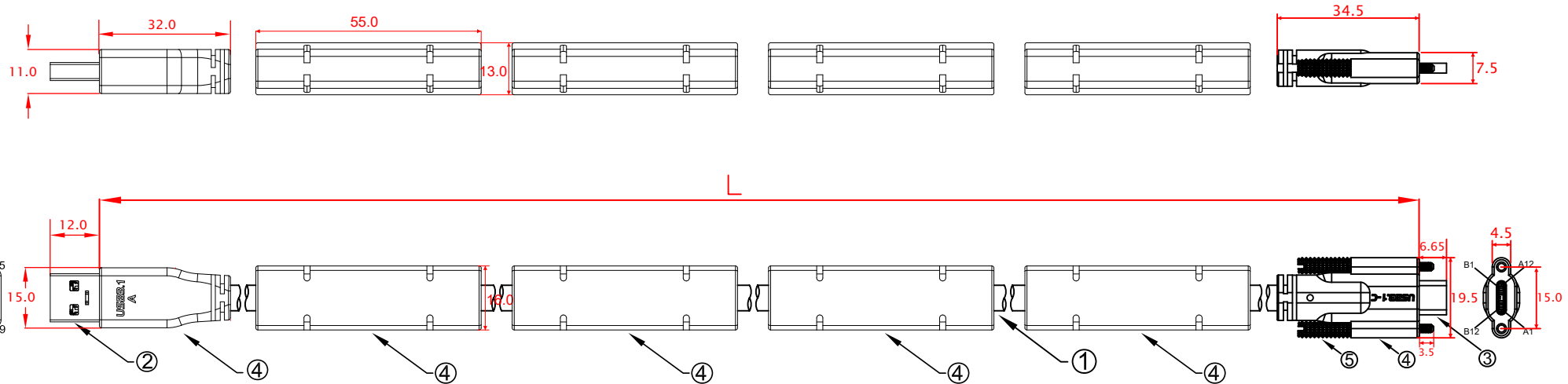

L:
 CBL-HFD3SAB5CS-10m 10000mm±50mm
 CBL-HFD3SAB5CS-11m 11000mm±50mm
 CBL-HFD3SAB5CS-12m 12000mm±50mm

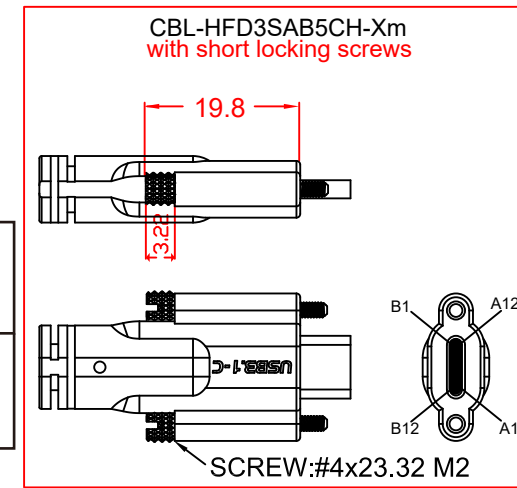
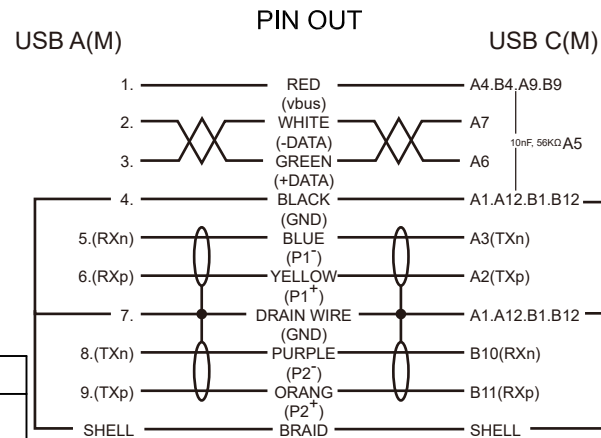

No	MATERIALS LIST:
1.	CABLE: 3 x (2 x 28 AWG)ST + 2 x 26 AWG O.D.:.6.1mm COLOR:RED LILAC
2.	CONNECTOR:USB 3.0 A/M, 9P, BLUE INSULATOR SOLDER TYPE, NICKEL PLATED SHELL
3.	CONNECTOR:USB 3.1 TYPE-C, MALE, NICKEL PLATED SHELL
4.	PVC MOLDED HOUSING, BLACK COLOR
5.	SCREW:#4x33 M2

Jargy part no.	Client part no.	Approved	SCALE	UNIT
CBL-HFD3SAB5CS-xm				mm
Drawing Name		Drawn	Date	REV.
USB 3.1 GEN 1 A to C Cable M/M				1,0

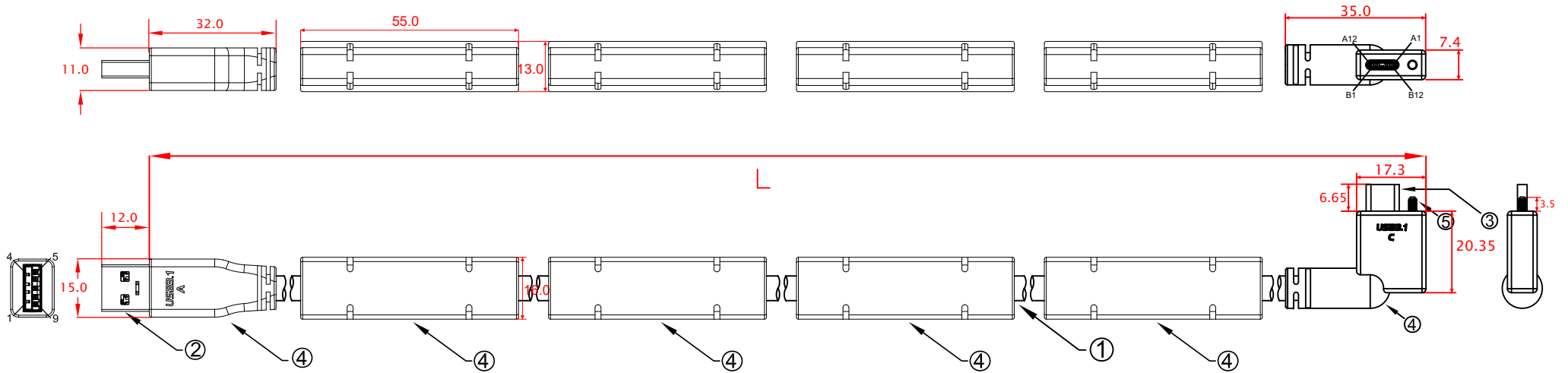

L:
 CBL-HFD3SAB5CH-10mLRA 10000mm±50mm
 CBL-HFD3SAB5CH-11mLRA 11000mm±50mm
 CBL-HFD3SAB5CH-12mLRA 12000mm±50mm

No	MATERIALS LIST:
1.	CABLE: 3 x (2 x 28 AWG)ST + 2 x 26 AWG O.D.:.6.1mm COLOR:RED LILAC
2.	CONNECTOR:USB 3.0 A/M, 9P, BLUE INSULATOR SOLDER TYPE, NICKEL PLATED SHELL
3.	CONNECTOR:USB 3.1 TYPE-C, MALE, NICKEL PLATED SHELL
4.	PVC MOLDED HOUSING, BLACK COLOR
5.	SCREW:#4x23.32 M2

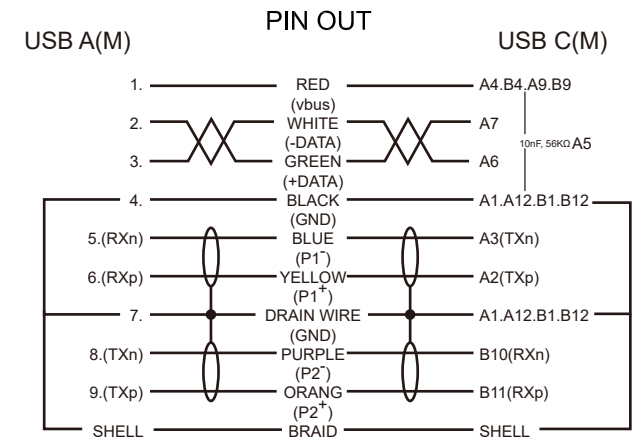

Jargy part no.	Client part no.	Approved	SCALE	UNIT
CBL-HFD3SAB5CH-xmLRA				mm
Drawing Name		Drawn	Date	REV.
USB 3.1 GEN 1 A to C Cable M/M				1,0

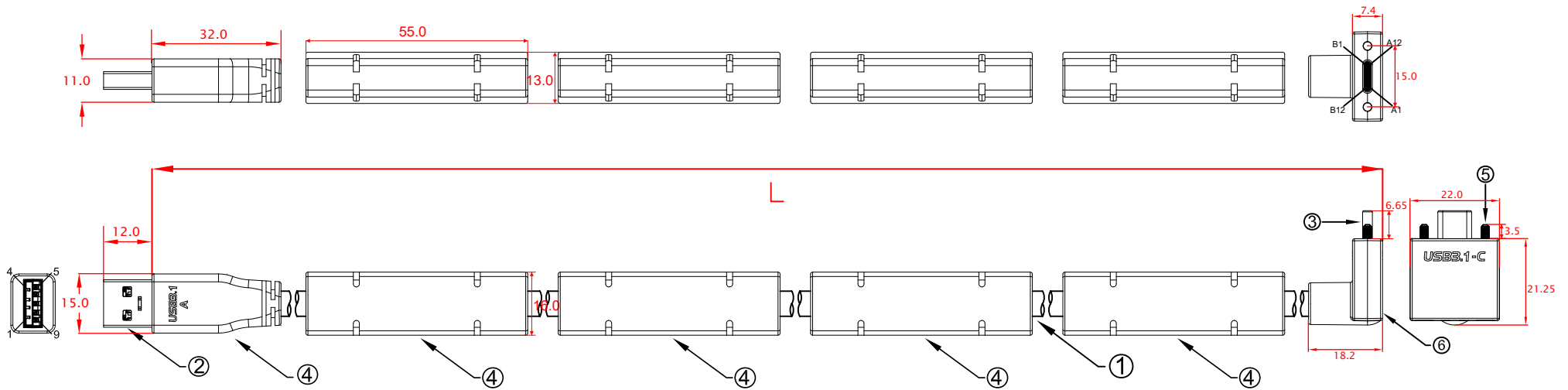

L:
 CBL-HFD3SAB5CH-10mUDA 10000mm±50mm
 CBL-HFD3SAB5CH-11mUDA 11000mm±50mm
 CBL-HFD3SAB5CH-12mUDA 12000mm±50mm

No	MATERIALS LIST:
1.	CABLE: 3 x (2 x 28 AWG)ST + 2 x 26 AWG O.D.:6.1mm COLOR:RED LILAC
2.	CONNECTOR:USB 3.0 A/M, 9P, BLUE INSULATOR SOLDER TYPE, NICKEL PLATED SHELL
3.	CONNECTOR:USB 3.1 TYPE-C, MALE, NICKEL PLATED SHELL
4.	PVC MOLDED HOUSING, BLACK COLOR
5.	SCREW:#4x23.32 M2
6.	ABS ASSEMBLY HOUSING, BLACK COLOR

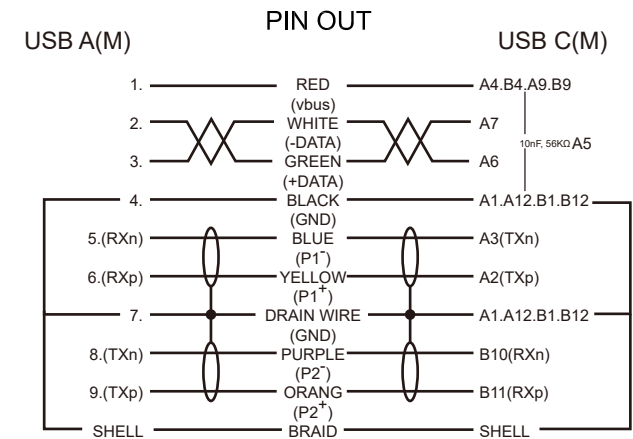

Jargy part no.	Client part no.	Approved	SCALE	UNIT
CBL-HFD3SAB5CH-xmUDA				mm
Drawing Name		Drawn	Date	REV.
USB 3.1 GEN 1 A to C Cable M/M				1,0

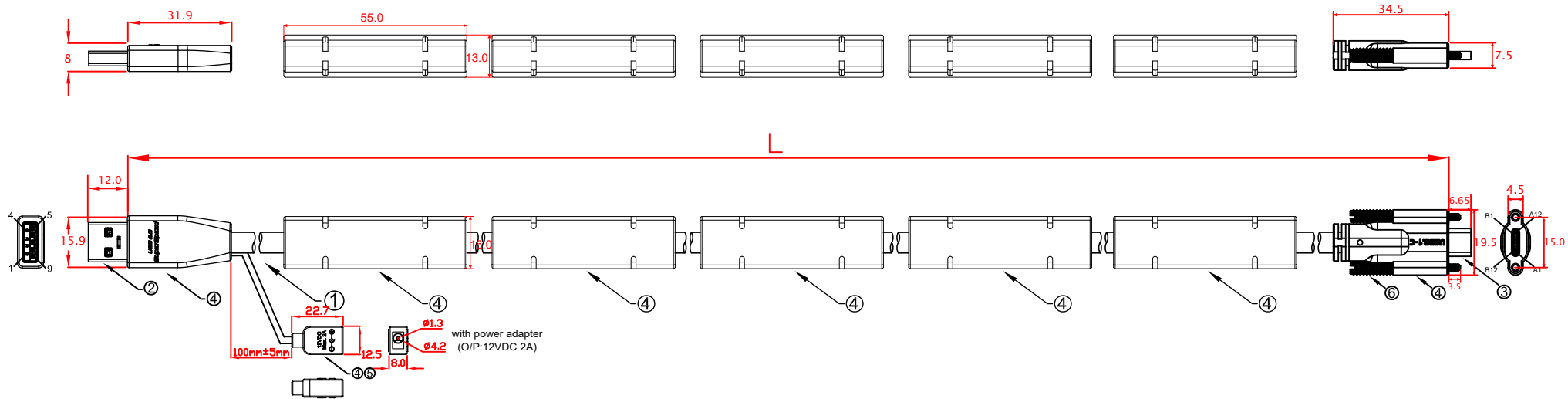

- L:
 CBL-HFD3SAB5CSPW-13m 13000mm±50mm
 CBL-HFD3SAB5CSPW-14m 14000mm±50mm
 CBL-HFD3SAB5CSPW-15m 15000mm±50mm

No	MATERIALS LIST:
1.	CABLE: 3 x (2 x 28 AWG)ST + 2 x 26 AWG O.D.:6.1mm COLOR:RED LILAC
2.	CONNECTOR:USB 3.0 A/M, 9P, BLUE INSULATOR SOLDER TYPE, NICKEL PLATED SHELL
3.	CONNECTOR:USB 3.1 TYPE-C, MALE, NICKEL PLATED SHELL
4.	PVC MOLDED HOUSING, BLACK COLOR
5.	DC JACK 1.3mm 30V 0.3V
6.	SCREW:#4x33 M2

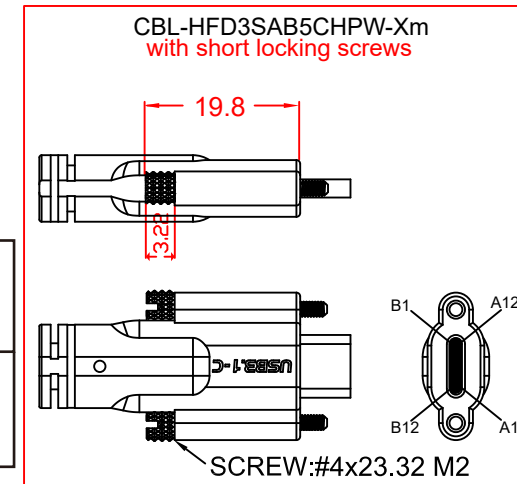
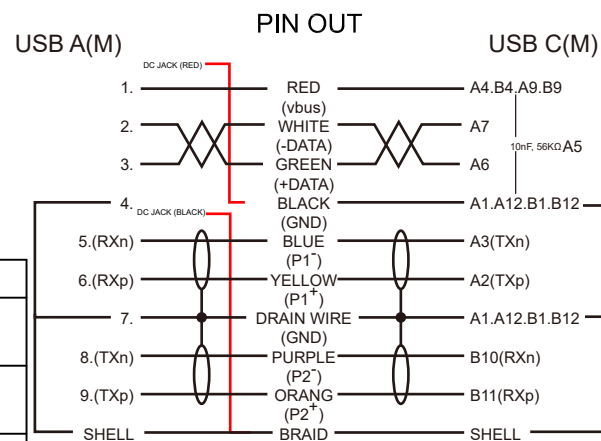

Jargy part no.	Client part no.	Approved	SCALE	UNIT
CBL-HFD3SAB5CSPW-xm				mm
Drawing Name		Drawn	Date	REV.
USB 3.1 GEN 1 A to C Cable M/M				1.0

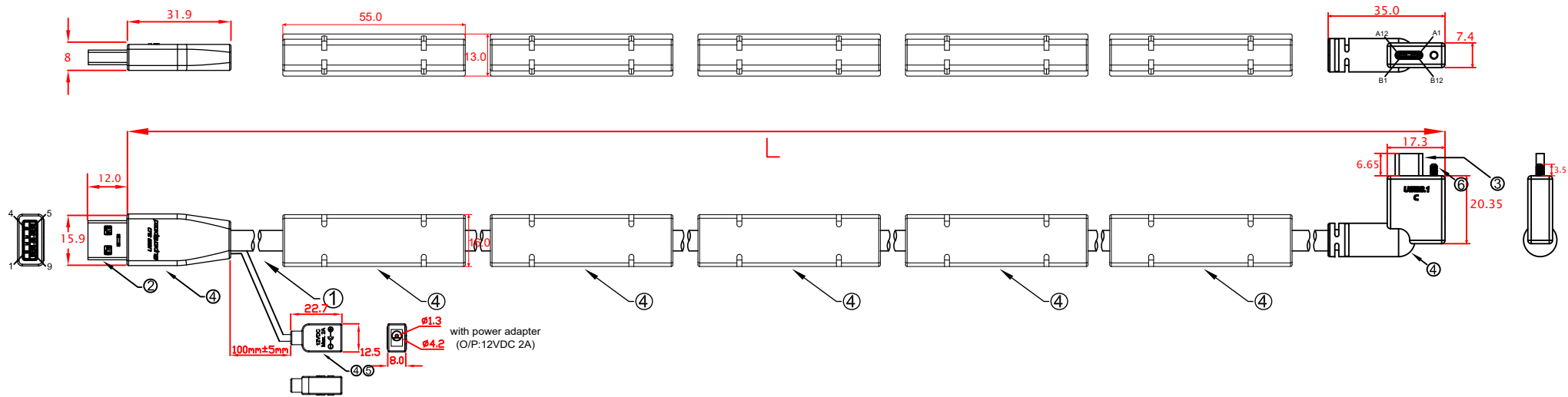

- L:
 CBL-HFD3SAB5CHPW-13mLRA 13000mm±50mm
 CBL-HFD3SAB5CHPW-14mLRA 14000mm±50mm
 CBL-HFD3SAB5CHPW-15mLRA 15000mm±50mm

No	MATERIALS LIST:
1.	CABLE: 3 x (2 x 28 AWG)ST + 2 x 26 AWG O.D.:.6.1mm COLOR:RED LILAC
2.	CONNECTOR:USB 3.0 A/M, 9P, BLUE INSULATOR SOLDER TYPE, NICKEL PLATED SHELL
3.	CONNECTOR:USB 3.1 TYPE-C, MALE, NICKEL PLATED SHELL
4.	PVC MOLDED HOUSING, BLACK COLOR
5.	DC JACK 1.3mm 30V 0.3V
6.	SCREW:#4x23.32 M2

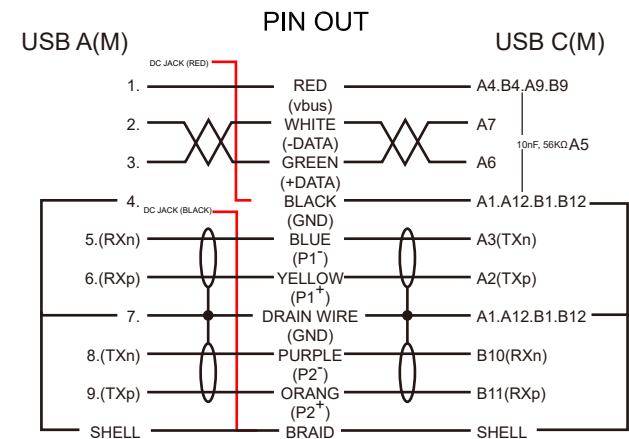

Jargy part no.	Client part no.	Approved	SCALE	UNIT
CBL-HFD3SAB5CHPW-xmLRA				mm
Drawing Name		Drawn	Date	REV.
USB 3.1 GEN 1 A to C Cable M/M				1.0

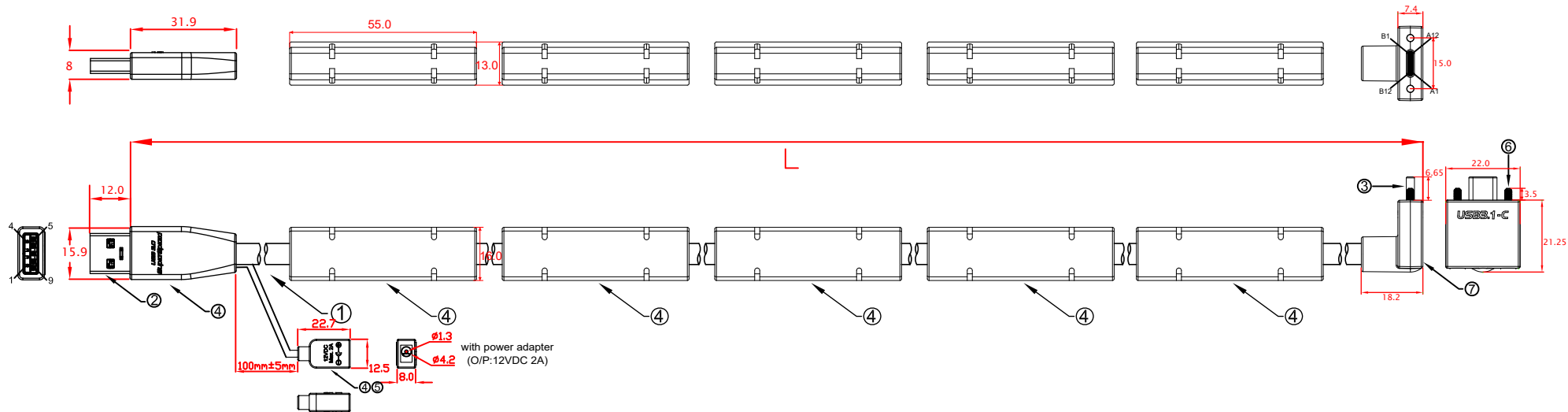

- L:
 CBL-HFD3SAB5CHPW-13mUDA 13000mm±50mm
 CBL-HFD3SAB5CHPW-14mUDA 14000mm±50mm
 CBL-HFD3SAB5CHPW-15mUDA 15000mm±50mm

No	MATERIALS LIST:
1.	CABLE: 3 x (2 x 28 AWG)ST + 2 x 26 AWG O.D.:.6.1mm COLOR:RED LILAC
2.	CONNECTOR:USB 3.0 A/M, 9P, BLUE INSULATOR SOLDER TYPE, NICKEL PLATED SHELL
3.	CONNECTOR:USB 3.1 TYPE-C, MALE, NICKEL PLATED SHELL
4.	PVC MOLDED HOUSING, BLACK COLOR
5.	DC JACK 1.3mm 30V 0.3V
6.	SCREW:#4x23.32 M2
7.	ABS ASSEMBLY HOUSING, BLACK COLOR

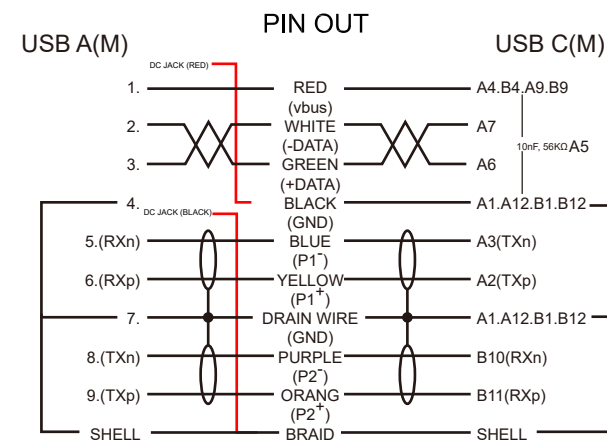

Jargy part no.	Client part no.	Approved	SCALE	UNIT
CBL-HFD3SAB5CHPW-xmUDA				mm
Drawing Name		Drawn	Date	REV.
USB 3.1 GEN 1 A to C Cable M/M				1.0

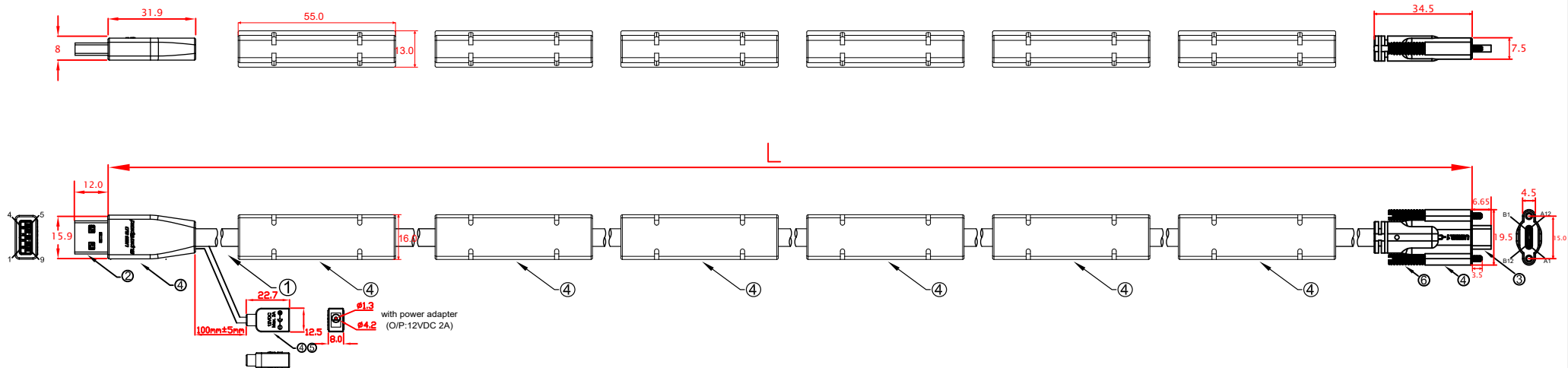

- L:
- CBL-HFD3SAB5CSPW-16m 16000mm±50mm
 - CBL-HFD3SAB5CSPW-17m 17000mm±50mm
 - CBL-HFD3SAB5CSPW-18m 18000mm±50mm
 - CBL-HFD3SAB5CSPW-19m 19000mm±50mm
 - CBL-HFD3SAB5CSPW-20m 20000mm±50mm

No	MATERIALS LIST:
1.	CABLE: 3 x (2 x 28 AWG)ST + 2 x 26 AWG O.D.:.6.1mm COLOR:RED LILAC
2.	CONNECTOR:USB 3.0 A/M, 9P, BLUE INSULATOR SOLDER TYPE, NICKEL PLATED SHELL
3.	CONNECTOR:USB 3.1 TYPE-C, MALE, NICKEL PLATED SHELL
4.	PVC MOLDED HOUSING, BLACK COLOR
5.	DC JACK 1.3mm 30V 0.3V
6.	SCREW:#4x33 M2

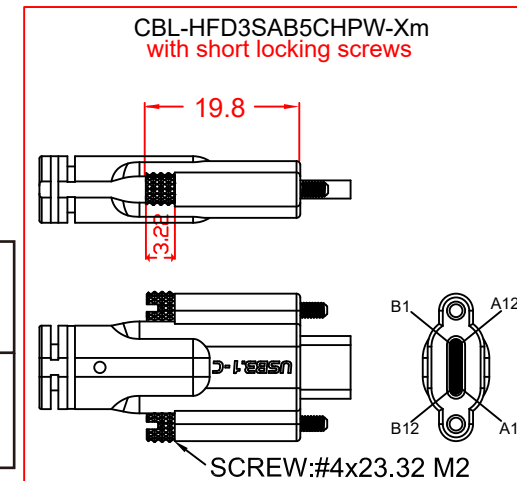
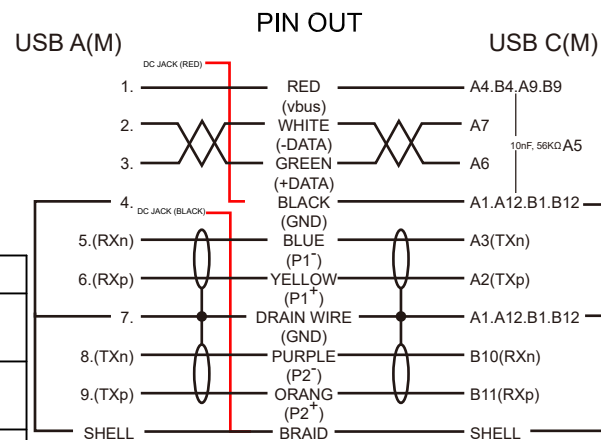

Jargy part no.	Client part no.	Approved	SCALE	UNIT
CBL-HFD3SAB5CSPW-xm				mm
Drawing Name		Drawn	Date	REV.
USB 3.1 GEN 1 A to C Cable M/M				1.0

Mobile Computing JARGY

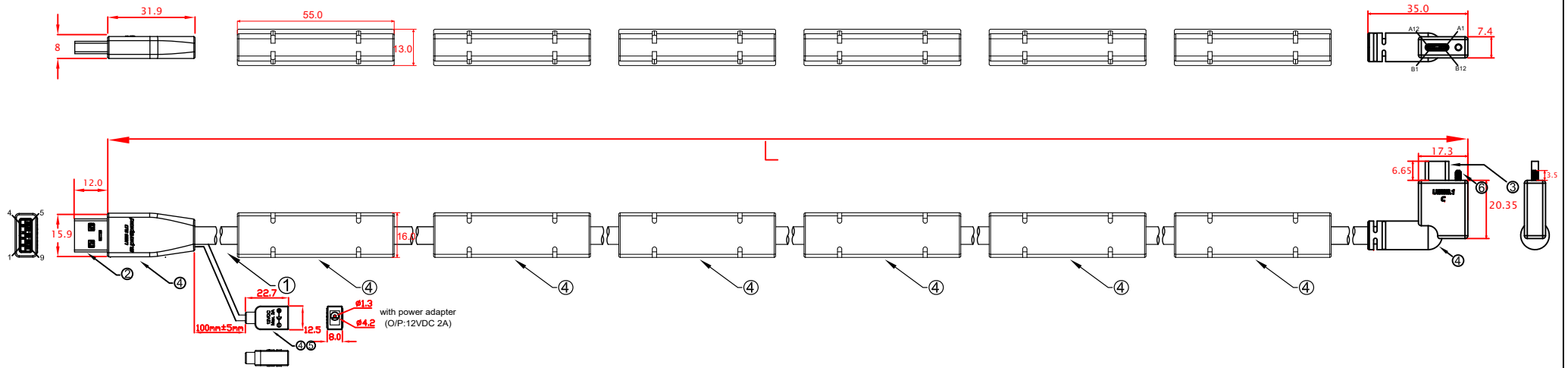

- L:
- | | |
|-------------------------|--------------|
| CBL-HFD3SAB5CHPW-16mLRA | 16000mm±50mm |
| CBL-HFD3SAB5CHPW-17mLRA | 17000mm±50mm |
| CBL-HFD3SAB5CHPW-18mLRA | 18000mm±50mm |
| CBL-HFD3SAB5CHPW-19mLRA | 19000mm±50mm |
| CBL-HFD3SAB5CHPW-20mLRA | 20000mm±50mm |

No	MATERIALS LIST:
1.	CABLE: 3 x (2 x 28 AWG)ST + 2 x 26 AWG O.D.:.6.1mm COLOR:RED LILAC
2.	CONNECTOR:USB 3.0 A/M, 9P, BLUE INSULATOR SOLDER TYPE, NICKEL PLATED SHELL
3.	CONNECTOR:USB 3.1 TYPE-C, MALE, NICKEL PLATED SHELL
4.	PVC MOLDED HOUSING, BLACK COLOR
5.	DC JACK 1.3mm 30V 0.3V
6.	SCREW:#4x23.32 M2

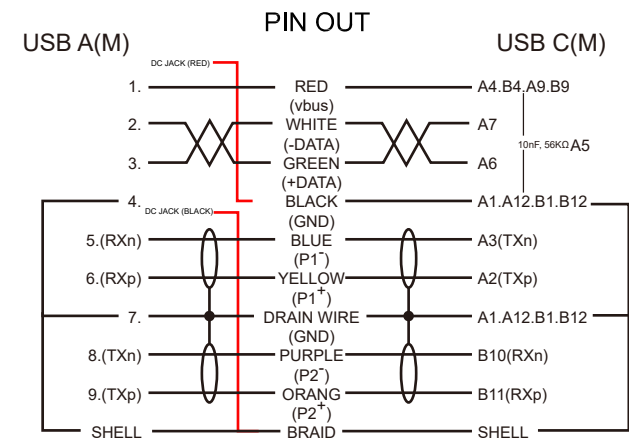

Jargy part no.	Client part no.	Approved	SCALE	UNIT
CBL-HFD3SAB5CHPW-xmlRA				mm
Drawing Name		Drawn	Date	REV.
USB 3.1 GEN 1 A to C Cable M/M				1.0

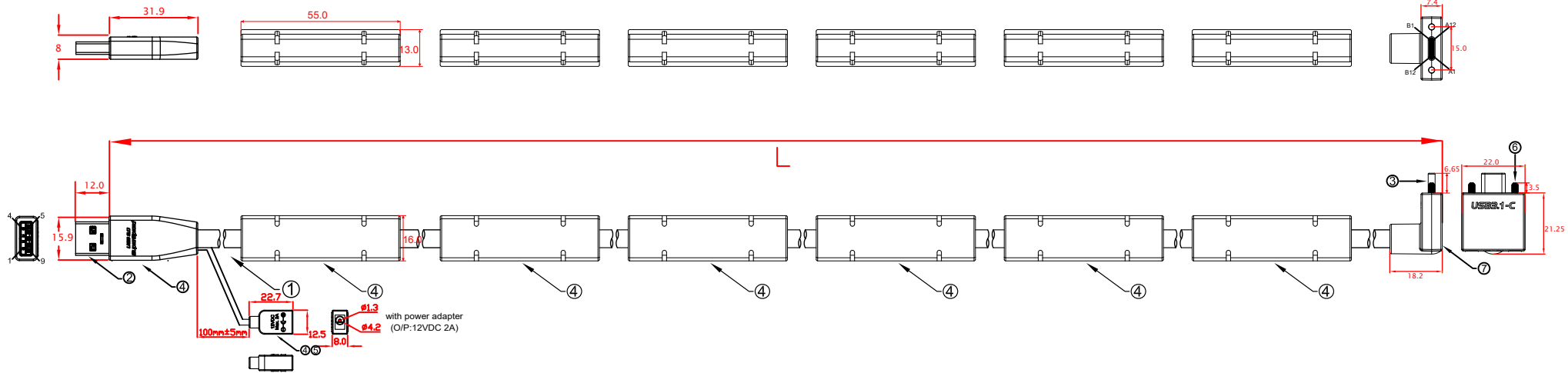

- L:
- CBL-HFD3SAB5CHPW-16mUDA 16000mm±50mm
 - CBL-HFD3SAB5CHPW-17mUDA 17000mm±50mm
 - CBL-HFD3SAB5CHPW-18mUDA 18000mm±50mm
 - CBL-HFD3SAB5CHPW-19mUDA 19000mm±50mm
 - CBL-HFD3SAB5CHPW-20mUDA 20000mm±50mm

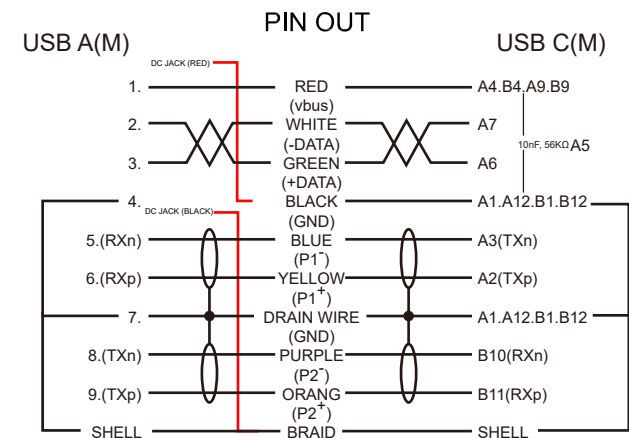

No	MATERIALS LIST:
1.	CABLE: 3 x (2 x 28 AWG)ST + 2 x 26 AWG O.D.:.6.1mm COLOR:RED LILAC
2.	CONNECTOR:USB 3.0 A/M, 9P, BLUE INSULATOR SOLDER TYPE, NICKEL PLATED SHELL
3.	CONNECTOR:USB 3.1 TYPE-C, MALE, NICKEL PLATED SHELL
4.	PVC MOLDED HOUSING, BLACK COLOR
5.	DC JACK 1.3mm 30V 0.3V
6.	SCREW:#4x23.32 M2
7.	ABS ASSEMBLY HOUSING, BLACK COLOR

Jargy part no.	Client part no.	Approved	SCALE	UNIT
CBL-HFD3SAB5CHPW-xmUDA				mm
Drawing Name		Drawn	Date	REV.
USB 3.1 GEN 1 A to C Cable M/M				1.0